

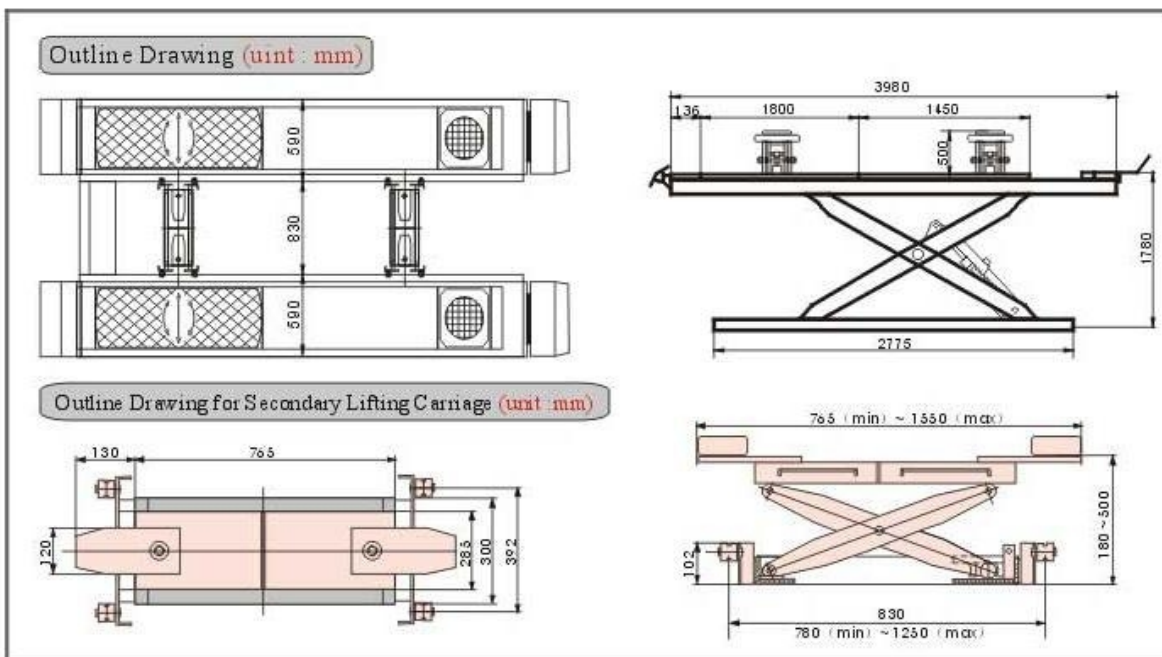

tool box

 pneumatic double rack
 self lock safety security
 unit

 the secondary lifting
 carriage

 steel rope mechanical
 synchronous system

Model	GL3500
Voltage	380V/50Hz
Power	2.2Kw
Pneumatic	6-8Kg/cm ²
Main machine lifting weight	3500Kg
Main machine lifting height	310-1780mm
Secondary Lifting Weight	2000Kg
Secondary Lifting Height	500mm
Equipment weight	1800Kg

Feature:

- 1 Low profile lift design save floor space.
- 2 Mechanical torsion bar design for synchronization lifting and safety.
- 3 Two roller jacks for wheel free operations.
- 4 Double air and mechanical locks for double lift safety.
- 5 Imported Italian hydraulic unit for durability and low noise.
- 6 Adjustable front recesses level and position for variety vehicles ;
- 7 Front sliding work tables for holding wheel service tool.
- 8 Lubrication point on all pivot points for easy maintenance and long life