

GL-4.0-2F1 hydraulic Two gantry lift



Features:

1. Import hydraulic power unit.
2. Clear floor space with the baseless lift design Stable lifting movement with the hydraulic power on one piece formed steel post.
3. Double safety with double locking devices on lifting chain and cable on both posts.
4. Safety sensor for maximum lifting height to protect vehicle from hitting top cross frame.
5. Powder coating process for better finishing and protection.

Outline Drawing (Unit:mm)

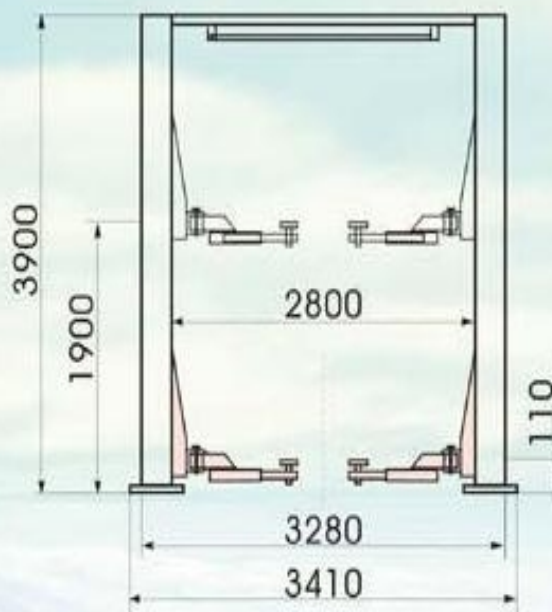
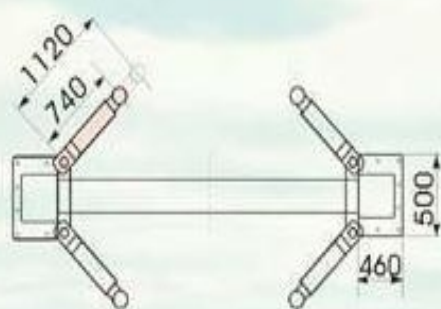

Technical specifications:

Model	Parameter	Max. lifting weight(Kg)	Max. lifting height(m.m)	Voltage(V)	Frequency (Hz)	Motor power(Kw)	Gross Weight(kg)
GL-QJY-2F1		4000	1900	380	50	2.2	900